

Transmission electrical testing

Test requirements:

- Battery Positive Voltage (B+) OK
- Fuses 14 (S14) and 21 (S21) OK
- Transmission Ground (GND) connections OK:
 - ◆ Ground (GND) connection located on left next to relay panel
 - Check Ground connections for corrosion and poor contact; repair if necessary.
 - Check Battery Ground (GND) strap as well as Ground (GND) strap between Battery and transmission.

Note:

- ◆ *Use the hand multimeter (Fluke 83, VAG 1526 or equivalent) for testing.*

- ◆ *Use auxiliary cables from the VAG 1594 adapter kit, and the test box as specified, for connecting test equipment.*

CAUTION!

To avoid damaging the electronic components, select the appropriate function and measurement range on the test equipment before connecting the test leads.

Note:

- ◆ *The specified values are valid for ambient temperatures ranging from 0-40° C (32-104° F).*
- ◆ *If the measured values differ from the specified values, determine the cause by using the wiring diagrams.*
- ◆ *If the measured values differ only slightly from the specified values, clean the sockets and connectors of the test equipment and test leads, then repeat the test. Before replacing a particular component, test the wiring and connections and, particularly if specified values are below 10 ohms (10Ω), repeat the resistance measurement.*

Electrical testing on Transmission Control Module with 38-pin connector ⇒ [page 01-69](#)

Electrical testing on Transmission Control Module with 68-pin connector ⇒ [page 01-81](#)

Electrical testing on Transmission Control Module (TCM) with 38-pin connector

Transmission Control Module (TCM) -J217- location

- ◆ Up to 12.92: in front of the front passenger seat under floor covering
- ◆ From 01.93: under the rear seat.

Wiring from the 38-pin TCM connector can be checked according to the wiring diagram using the VAG 1598 test box.

- Switch ignition OFF.
- Disconnect multi-pin connector from Transmission Control Module (TCM) -J217-.
- Connect VAG 1598 test box to connector using VAG 1598/9 adapter.

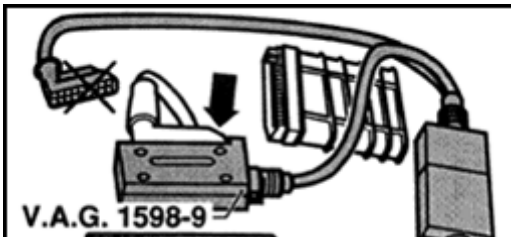

A

Resistance measurements:

- ◆ VAG 1598/9 adapter disconnected from Transmission Control Module (TCM)

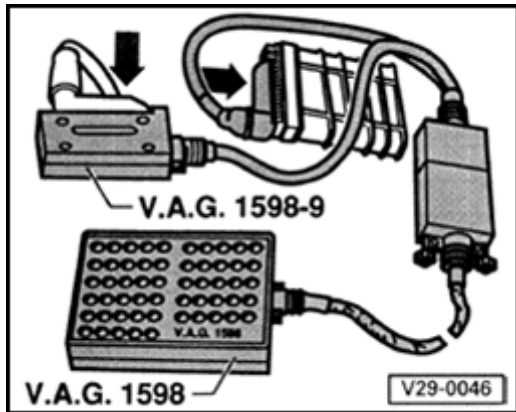

▲ Voltage measurements:

- ◆ VAG 1598/9 adapter connected to Transmission Control Module (TCM)

Terminal assignment for 38-pin Transmission Control Module (TCM) -J217- connector(also sockets on VAG 1598 test box)

- 1 - Ground (GND) (terminal 31)
- 2 - Solenoid Valve 4 -N91-
- 3 - Solenoid Valve 3 -N90-
- 4 - Not assigned
- 5 - Park/Neutral signal
- 6 - K-wire for On Board Diagnostic
- 7 - Not assigned
- 8 - Kickdown for air conditioner
- 9 - Throttle Position (TP) Sensor -G69-
- 10 - Throttle Position (TP) Sensor -G69- 1)
- 11 - Not assigned
- 12 - Selector lever display -or- not assigned
- 13 - Vehicle Speed Sensor (VSS) -G68- screening
- 14 - Not assigned
- 15 - Multi-Function Transmission Range (TR) Switch -F125-

- 16 - Multi-Function Transmission Range (TR) Switch -F125-
- 17 - Kick Down Switch -F8-
- 18 - Battery Positive Voltage (B+) supply for Solenoid Valves
- 19 - Battery Positive Voltage (B+) (terminal 15)
- 21 - Solenoid Valve 7 -N94-
- 22 - Solenoid Valve 1 -N88-
- 23 - Solenoid Valve 2 -N89-
- 24 - Solenoid Valve 5 -N92-
- 25 - Solenoid Valve 6 -N93-
- 26 - Brake Light Switch -F- signal voltage
- 27 - Engine = TD-(RPM) signal
- 28 - Engine = Ignition timing influence
- 29 - Throttle Position (TP) Sensor -G69- Ground (GND) 1)
- 30 - Transmission fluid (ATF) temperature
- 31 - Not assigned
- 32 - Vehicle Speed Sensor (VSS) -G68-
- 33 - Vehicle Speed Sensor (VSS) -G68-
- 34 - Multi-Function Transmission Range (TR) Switch -F125-

35 - Multi-Function Transmission Range (TR) Switch -F125-

36 - Transmission Range (TR) Program Switch -E122- or electronic program switch

37 - Idle switch

38 - Cruise control system

1) Voltage supply (contacts 10 and ²⁹) not assigned on vehicles with 6-cylinder engine; Throttle Position (TP) Sensor signal (terminal ⁹) is routed to the Transmission Control Module (TCM) via the Motronic Engine Control Module (ECM).

List of test steps (TCM with 38-pin connector)

Note:

Only carry out test steps listed in Diagnostic Trouble Code (DTC) table, or referred to while reading measured value block.

Component checked		Component checked	
Battery Positive Voltage (B+) supply from Transmission Control Module (TCM) -J217-	- Carry out test step 1	Solenoid Valve 5 -N92-	- Carry out test step 10
Throttle Position (TP) Sensor -G69-	- Carry out test step 2	Solenoid Valve 6 -N93-	- Carry out test step 11
Shiftlock Solenoid -N110-	- Carry out test step 3	Solenoid Valve 7 -N94-	- Carry out test step 12
Brake Light Switch -F-	- Carry out test step 4	Kick Down Switch -F8-	- Carry out test step 14
Multi-Function Transmission Range (TR) Switch -F125-	- Carry out test step 5	Vehicle Speed Sensor -G68-	- Carry out test step 15
Solenoid Valve 1 -N88-	- Carry out test step 6	Transmission Fluid Temperature Sensor -G93-	- Carry out test step 16
Solenoid Valve 2 -N89-	- Carry out test step 7	Transmission Range (TR) Program Switch -E122-	- Carry out test step 17
Solenoid Valve 3 -N90-	- Carry out test step 8		

Solenoid Valve 4 -N91-

- Carry out
test step 9

Test table

Switch to voltage measuring range 20 V					
Test step	VAG 1598 sockets	Test of	<ul style="list-style-type: none"> • Test conditions - Additional operations 	Specified value	Repairing malfunction
1	19 + 1	Supply voltage from Transmission Control Module (TCM) -J217-	<ul style="list-style-type: none"> • Ignition switched ON 	approx. Battery Positive Voltage (B+)	<ul style="list-style-type: none"> - Check wiring according to wiring diagram - Check wiring from pin 1 to Ground (GND) - Check wiring from pin19 to terminal 15 central electrics

Switch to voltage measuring range 20 V					
Test step	VAG 1598 sockets	Test of	<ul style="list-style-type: none"> • Test conditions - Additional operations	Specified value	Repairing malfunction
2	10 + 29	Throttle Position (TP) Sensor -G69- 1)	<ul style="list-style-type: none"> • Ignition switched ON - Disconnect connector from Throttle Position (TP) Sensor	4.6 to 5 V	<ul style="list-style-type: none"> - Check routing of wiring according to wiring diagram - Replace Transmission Control Module (TCM) -J217- ⇒ page 01-7 - Bring system into basic setting ⇒ page 01-43
	9 + 29		<ul style="list-style-type: none"> • Ignition switched ON 		When accelerating from idle to full throttle, voltage level increases constantly <ul style="list-style-type: none"> - Check Throttle Position (TP) Sensor, replace if necessary ⇒ <i>Repair Manual, 2.0 Liter Fuel Injection & Ignition or 1.8 Liter Fuel Injection & Ignition, Repair Group 24</i> <ul style="list-style-type: none"> - Bring system into basic setting ⇒ page

					01-43
			Idling - min.	0.156 V	
			Idling - max.	0.8 V	
			Wide Open Throttle - min.	3.5 V	
			- max.	4.68 V	

1) Engine with Mono-Motronic: Engine Coolant Temperature (ECT) min. 80 ° C (176 ° F).

Not checked on vehicles with 6-cylinder engine; Signal from TP Sensor -G69- is directed to TCM via ECM and can only be measured by the "Reading measured value block" function using the VAG 1551 Scan Tool ⇒ [page 01-45](#)

Switch to voltage measuring range 20 V					
Test step	VAG 1598 sockets	Test of	<ul style="list-style-type: none"> • Test conditions - Additional operations 	Specified value	Repairing malfunction
3	19 + 20	Shiftlock Solenoid - N110-	<ul style="list-style-type: none"> • Ignition switched ON • Selector lever in position P or N 	approx. Battery Positive Voltage (B+)	<ul style="list-style-type: none"> - Check wiring according to wiring diagram - Replace Transmission Control Module (TCM) -J217- ⇒ page 01-7 - Bring system into basic setting ⇒ page 01-43
			<ul style="list-style-type: none"> • With brake operated 	0 V	<ul style="list-style-type: none"> - Carry out test step 4; if necessary replace Transmission Control Module (TCM) -J217- ⇒ page 01-7 - Bring system into basic setting ⇒ page 01-43
4	26 + 1	Brake Light Switch -F-	<ul style="list-style-type: none"> • Ignition switched ON • Brake pedal not depressed 	0 V	<ul style="list-style-type: none"> - Check wiring according to wiring diagram - Replace Brake Light Switch -F-
			- Brake pedal	approx. Battery	

depressed

Positive Voltage
(B+)

Switch to voltage measuring range 20 V

Test step	VAG 1598 sockets	Test of	<ul style="list-style-type: none"> • Test conditions - Additional operations 	Specified value	Repairing malfunction
5	34 + 1	Multi-Function Transmission Range (TR) Switch -F125-	<ul style="list-style-type: none"> • Ignition switched ON - Selector lever positions R, N, D, 3 and 2 	4.5 to 5 V	<ul style="list-style-type: none"> - Check wiring according to wiring diagram - Check Multi-Function TR Switch -F125- for contact corrosion and replace if necessary - Replace Multi-Function TR Switch -F125- ⇒ page 01-18, Fig. 22 , Fig. 22
			<ul style="list-style-type: none"> - Selector lever positions P and 1 	0 to 0.8 V	
			<ul style="list-style-type: none"> - Selector lever positions P, R 2 and 1 	4.5 to 5 V	
			<ul style="list-style-type: none"> - Selector lever positions N, D and 3 	0 to 0.8 V	
	15 + 1				

35 + 1	- Selector lever positions P, R, N and D	4.5 to 5 V
	- Selector lever positions 3, 2 and 1	0 to 0.8 V
16 + 1	- Selector lever positions P, R, and N	approx. Battery Positive Voltage (B+)
	- Selector lever positions D, 3, 2 and 1	0 to 0.8 V

Switch to resistance measuring range 200 Ω

Test step	VAG 1598 sockets	Test of	<ul style="list-style-type: none"> • Test conditions - Additional operations 	Specified value	Repairing malfunction
6	22 + 18	Solenoid Valve 1 -N88-	<ul style="list-style-type: none"> • Ignition switched OFF • Transmission Control Module (TCM) -J217- disconnected 	55 to 65 Ω	- Check routing of wiring according to wiring diagram
	22 + 1			infinite Ω 1)	- Replace valve body \Rightarrow page 38-36
7	23 + 18	Solenoid Valve 2 -N89-	<ul style="list-style-type: none"> • Ignition switched OFF • TCM -J217- disconnected 	55 to 65 Ω	- Check routing of wiring according to wiring diagram
	23 + 1			infinite Ω 1)	- Replace valve body \Rightarrow page 38-36
8	3 + 18	Solenoid Valve 3 -N90-	<ul style="list-style-type: none"> • Ignition switched OFF • TCM -J217- disconnected 	55 to 65 Ω	- Check routing of wiring according to wiring diagram
	3 + 1			infinite Ω 1)	- Replace valve body \Rightarrow page 38-36
9	2 + 18	Solenoid Valve 4 -N91-	<ul style="list-style-type: none"> • Ignition switched OFF 	55 to 65 Ω	- Check routing of wiring according to wiring

2 + 1

- TCM -J217-
disconnected

infinite
 Ω 1)

diagram

- Replace valve body \Rightarrow
[page 38-36](#)

1) Switch multimeter to largest Ω (Ohms) range

Switch to resistance measuring range 200 Ω

Test step	VAG 1598 sockets	Test of	<ul style="list-style-type: none"> • Test conditions - Additional operations 	Specified value	Repairing malfunction
10	24 + 18	Solenoid Valve 5 -N92-	<ul style="list-style-type: none"> • Ignition switched OFF • Transmission Control Module (TCM) -J217- disconnected 	55 to 65 Ω	<ul style="list-style-type: none"> - Check routing of wiring according to wiring diagram - Replace valve body \Rightarrow page 38-36
	24 + 1			infinite Ω 1)	
11	25 + 18	Solenoid Valve 6 -N93-	<ul style="list-style-type: none"> • Ignition switched OFF • TCM -J217- disconnected 	4.5 to 6.5 Ω	<ul style="list-style-type: none"> - Check routing of wiring according to wiring diagram - Replace valve body \Rightarrow page 38-36
	25 + 1			infinite Ω 1)	
12	21 + 18	Solenoid Valve 7 -N94-	<ul style="list-style-type: none"> • Ignition switched OFF • TCM -J217- 	55 to 65 Ω	<ul style="list-style-type: none"> - Check routing of wiring according to wiring diagram - Replace valve body \Rightarrow page 38-36
	21+ 1			infinite	

			disconnected	Ω 1)	
13	19 + 20	Shiftlock Solenoid - N110-	<ul style="list-style-type: none"> Ignition switched OFF TCM -J217- disconnected 	14 to 25 Ω	<ul style="list-style-type: none"> - Check routing of wiring according to wiring diagram - Replace Shiftlock Solenoid -N110- ⇒ Selector mechanism, servicing, page 37-1

1) Switch multimeter to largest Ω (Ohms) range

Switch to resistance measuring range 200 Ω					
Test step	VAG 1598 sockets	Test of	<ul style="list-style-type: none"> • Test conditions - Additional operations 	Specified value	Repairing malfunction
14	1 + 17	Kick Down Switch -F8-	<ul style="list-style-type: none"> • Ignition switched OFF • Transmission Control Module (TCM) -J217- disconnected • Accelerator Pedal NOT depressed 	infinite Ω 1)	<ul style="list-style-type: none"> - Check routing of wiring according to wiring diagram - Adjust Accelerator Pedal cable, or replace <p><i>⇒ Repair Manual, 2.0 Liter General, Engine, 1.8 Liter General, Engine or 2.8 Liter VR6 General, Engine, Repair Group 20</i></p>
			<ul style="list-style-type: none"> - Depress Accelerator Pedal pressed down as far as kickdown 	less than 1.5 Ω	

1) Switch multimeter to largest Ω (Ohms) range

Switch to resistance measuring range 20 K Ω					
Test step	VAG 1598 sockets	Test of	<ul style="list-style-type: none"> • Test conditions - Additional operations 	Specified value	Repairing malfunction

15	32 + 33	Vehicle Speed Sensor (VSS) -G68-	<ul style="list-style-type: none"> • Ignition switched OFF • Transmission Control Module (TCM) -J217- disconnected 	min. max.	0.8 K Ω 0.9 K Ω	- Check wiring according to wiring diagram - Replace Vehicle Speed Sensor (VSS) -G68- \Rightarrow page 01-19, Fig. 23
----	---------	-------------------------------------	--	--------------	----------------------------------	--

Switch to resistance measuring range 2 M Ω

Test step	VAG 1598 sockets	Test of	<ul style="list-style-type: none"> • Test conditions - Additional operations 	Specified value	Repairing malfunction	
16	30 + 18	Transmission Fluid Temperature Sensor -G93-(ATF)	<ul style="list-style-type: none"> • Ignition switched OFF • Transmission Control Module (TCM) -J217- disconnected • Transmission fluid (ATF) temperature: approx. 20° C (68° F) 	0.247 M Ω	<ul style="list-style-type: none"> - Check wiring according to wiring diagram - Replace valve body ⇒ page 38-36 	
			- Switch to 200 K Ω measuring range			
			<ul style="list-style-type: none"> • Transmission fluid (ATF) temperature: approx. 60° C (140° F) approx. 120° C (248° F) 	48.8 K Ω 7.4 K Ω		

Switch to resistance measuring range 200 Ω					
Test step	VAG 1598 sockets	Test of	<ul style="list-style-type: none"> • Test conditions - Additional operations 	Specified value	Repairing malfunction
17	36 + 1	Transmission Range (TR) Program Switch -E122-	<ul style="list-style-type: none"> • Ignition switched OFF • Transmission Control Module (TCM) -J217- disconnected • TR Program Switch - E122- not operated 	infinite Ω 1)	<ul style="list-style-type: none"> - Check wiring according to wiring diagram - Replace TR Program Switch \Rightarrow page 01-22, Fig. 29
			- TR Program Switch - E122- operated	less than 1.5 Ω	

1) Switch multimeter to largest Ω (Ohms) range

Electrical testing on Transmission Control Module (TCM) with 68-pin connector

Test requirements, Cautions, notes

⇒ [page 01-67](#)

The Transmission Control Module (TCM) -J217- is located under the rear seat.

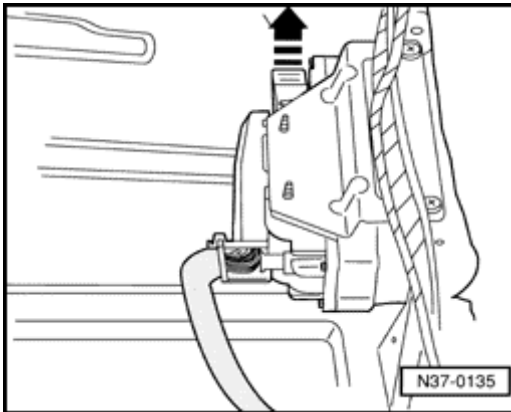

A

- Switch ignition off, release multi-pin connector lock in direction of -arrow-, then disconnect from control module.

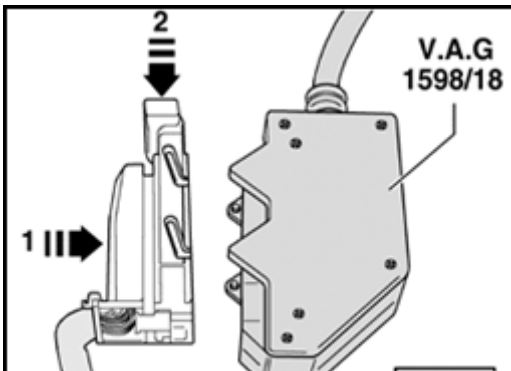

A

- Connect VAG 1598/18 test box to multi-pin connector -1- and lock, moving in direction of -arrow-.

Wiring to and from the 68-pin TCM connector can be checked according to the wiring diagram using the VAG 1598/18 test box.

After electrical checks:

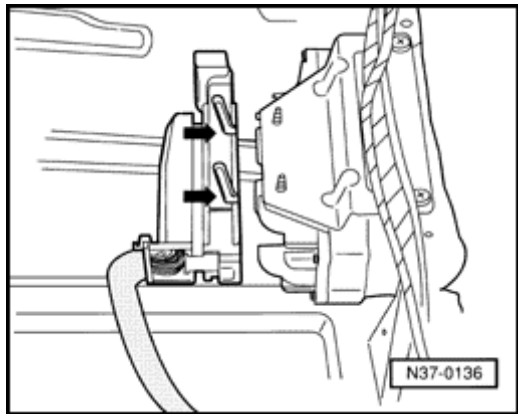

A

- Re-connect multi-pin connector to TCM and lock.

Note:

When re-connecting, make sure that the guides (arrows) are engaged with the TCM pins.

Terminal assignment for 68-pin Transmission Control Module (TCM) -J217- connector(also sockets on VAG 1598/18 test box)

1- Ground (GND) (terminal 31)	19- Engine TD-signal (RPM)
2- Not assigned	20- Vehicle Speed Sensor -G68-
3- Not assigned	21- Not assigned
4- Not assigned	22- Solenoid Valve 6 -N93- (supply voltage)
5- Throttle Position (TP) Sensor -G69- 1)	23- Battery Positive Voltage (B+) (terminal 15)
6- Transmission Fluid Temperature Sensor -G93-	24- On Board Diagnostic (OBD) K-wire
7- Not assigned	25- Not assigned
8- Not assigned	26- Not assigned
9- Solenoid Valve 3 -N90-	27- Not assigned
10- Solenoid Valve 7 -N94-	28- Throttle Position Sensor -G69- Ground (GND)1)
11- Park/Neutral Position (PNP) signal	29- Shiftlock Solenoid -N110-
12- Kickdown for air conditioner	30- Not assigned
13- Ignition timing influence	31- Not assigned
14- Not assigned	32- Not assigned
15- Brake Light Switch -F- (signal voltage)	33- Not assigned
16- Kick Down Switch -F8-	34- Not assigned
17- Not assigned	35- Not assigned
18- Multi-function Transmission Range (TR) Switch -F125-	36- On Board Diagnostic (OBD) L-wire

1) Signal contacts (5 and ²⁸) and regulated voltage supply contact (⁵⁰) not assigned on vehicles with 6-cylinder engine; Load

signal (contact ⁴¹) is directed to Transmission Control Module (TCM) via Motronic Engine Control Module (ECM) and can only be checked using the "Reading measured value block" function of the VAG 1551 Scan Tool (ST) ⇒ [page 01-45](#) .

37- Not assigned	53- Not assigned
38- Not assigned	54- Solenoid Valve 2 -N89-
39- Not assigned (by VW)	55- Solenoid Valve 1 -N88-
40- Multi-function Transmission Range (TR) Switch -F125-	56- Solenoid Valve 5 -N92-
41- Load signal from Motronic Engine Control Module (ECM)	57- Selector lever display
42- Diesel engine RPM sensor (screening)	58- Solenoid Valve 6 -N93-
43- Vehicle Speed Sensor -G68- (screening)	59- Not assigned
44- Not assigned	60- Cruise control system (input, terminal15)
45- Not assigned	61- Cruise control system (output)
46- Not assigned	62- Multi-function Transmission Range (TR) Switch -F125-
47- Solenoid Valve 4 -N91-	63- Multi-function Transmission Range (TR) Switch -F125-
48- Not assigned	64- Engine Speed (RPM) Sensor -G28-
49- Not assigned	65- Vehicle Speed Sensor -G68- (Diesel engine)
50- Throttle Position (TP) Sensor -G69- (5 volts) 1)	66- Not assigned
51- Not assigned	67- Solenoid Valves voltage supply
52- Not assigned	68- Not assigned

1) Signal contacts (5 and ²⁸) and regulated voltage supply contact (⁵⁰) not assigned on vehicles with 6-cylinder engine; Load signal (contact ⁴¹) is directed to Transmission Control Module (TCM) via Motronic Engine Control Module (ECM) and can only be checked using the "Reading measured value block" function of the VAG 1551 Scan Tool (ST) ⇒ [page 01-45](#) .

List of test steps (TCM with 68-pin connector)

Note:

Only carry out test steps as listed in Diagnostic Trouble Code (DTC) table, or referred to while reading measured value block.

Component checked		Component checked	
Battery Positive Voltage (B+) supply from Transmission Control Module (TCM) -J217-	- Carry out test step 1	Solenoid Valve 5 -N92-	- Carry out test step 10
Shiftlock Solenoid -N110-	- Carry out test steps 2 and 13	Solenoid Valve 6 -N93-	- Carry out test step 11
Brake Light Switch -F-	- Carry out test step 3	Solenoid Valve 7 -N94-	- Carry out test step 12
Throttle Position (TP) Sensor -G69-	- Carry out test step 4	Kick Down Switch -F8-	- Carry out test step 14
Multi-Function Transmission Range (TR) Switch -F125-	- Carry out test step 5	Vehicle Speed Sensor -G68-	- Carry out test step 15
Solenoid Valve 1 -N88-	- Carry out test step 6	Transmission Fluid Temperature Sensor -G93-	- Carry out test step 16
Solenoid Valve 2 -N89-	- Carry out test step 7		
Solenoid Valve 3 -N90-	- Carry out		

	test step 8		
Solenoid Valve 4 -N91-	- Carry out test step 9		

Test table

Switch to voltage measuring range 20 V					
Test step	VAG 1598/18 sockets	Test of	<ul style="list-style-type: none"> • Test conditions - Additional operations	Specified value	Repairing malfunction
1	23 + 1	Supply voltage from Transmission Control Module (TCM) -J217-	<ul style="list-style-type: none"> • Ignition switched ON 	approx. Battery Positive Voltage (B+)	<ul style="list-style-type: none"> - Check wiring according to wiring diagram - Check wiring from pin 1 to Ground (GND) - Check wiring from pin 23 to terminal 15 central electrics
2	29 + 15	Shiftlock Solenoid -N110-	<ul style="list-style-type: none"> • Ignition switched ON • Brake pedal NOT depressed 	approx. Battery Positive Voltage (B+)	<ul style="list-style-type: none"> - Check wiring according to wiring diagram - Replace Shiftlock Solenoid - N110- ⇒ Shift mechanism, servicing, page 37-1
			- Depress brake pedal	0.2 V	
3	15 + 1	Brake Light Switch -F-	<ul style="list-style-type: none"> • Ignition switched ON 	0 V	<ul style="list-style-type: none"> - Check wiring according to wiring diagram

			<ul style="list-style-type: none">• Brake pedal NOT depressed		<p>- Replace Brake Light Switch -F-</p> <p>⇒ <u>Repair Manual, Suspension, Wheels, Brakes, Steering, Repair Group 47</u></p>
			<p>- Depress brake pedal</p>	<p>approx. Battery Positive Voltage (B+)</p>	

Switch to resistance measuring range 20 K Ω					
Test step	VAG 1598/18 sockets	Test of	<ul style="list-style-type: none"> • Test conditions - Additional operations 	Specified value	Repairing malfunction
4	5 + 28	Throttle Position (TP) Sensor -G69- 1)	<ul style="list-style-type: none"> • Ignition switched OFF <p>Accelerator Pedal position:</p> <p>Idling</p> <p>- min.</p> <p>- max.</p>	<p>0.7 KΩ</p> <p>1.8 KΩ</p>	<p>- Check wiring according to wiring diagram</p> <p>When accelerating from idle to Wide Open Throttle, resistance measurement will constantly change</p> <p>- Adjust Throttle Position (TP) Sensor, and replace if necessary</p> <p><i>⇒ Repair Manual, 2.0 Liter Fuel Injection & Ignition or 1.8 Liter Fuel Injection & Ignition, Repair Group 24</i></p> <p>- Bring system into basic setting ⇒ page 01-43</p>

			Wide Open Throttle	
			- min.	2.1 K Ω
			- max.	3.9 K Ω
5 + 50	Throttle Position (TP) Sensor -G69- 1)	Accelerator Pedal position:		
		Idling		
		- min.	2.1 K Ω	
		- max.	3.9 K Ω	
		Wide Open Throttle		
		- min.	0.7 K Ω	
		- max.	1.8 K Ω	

1) Engine with Mono Motronic: Engine Coolant Temperature (ECT) min. 80 ° C (176 ° F).

Not checked on vehicles with 6-cylinder engine; Signal from TP Sensor -G69- is directed to TCM via ECM and can only be measured using the "Reading measured value block" function of the VAG 1551 Scan Tool ⇒ [page 01-45](#)

Switch to resistance measuring range 200 Ω

Test step	VAG 1598/18 sockets	Test of	<ul style="list-style-type: none"> • Test conditions - Additional operations 	Specified value	Repairing malfunction
5	63 + 1	Multi-Function Transmission Range (TR) Switch -F125-	- Selector lever positions R, N, D, 3 and 2	infinite Ω 1)	<ul style="list-style-type: none"> - Check wiring according to wiring diagram - Check connector on Multi-Function TR Switch -F125- for corrosion and replace if necessary - Replace Multi-Function TR Switch -F125- \Rightarrow page 01-18, Fig. 22
			- Selector lever positions P and 1	0.8 to 1 Ω	
	40 + 1		- Selector lever positions P, R, 2 and 1	infinite Ω 1)	
			- Selector lever positions N, D and 3	0.8 to 1 Ω	
	62 + 1		- Selector lever positions P, R, N and D	infinite Ω 1)	

		- Selector lever positions 3, 2 and 1	0.8 to 1 Ω
	18 + 1	- Switch to voltage measuring range 20 V	
		- Selector lever positions P, R, and N	approx. Battery Positive Voltage (B+)
		- Selector lever positions D, 3, 2 and 1	0 V

1) Switch multimeter to largest Ω (ohms) range

Switch to resistance measuring range 200 Ω					
Test step	VAG 1598/18 sockets	Test of	<ul style="list-style-type: none"> Test conditions - Additional operations	Specified value	Repairing malfunction
6	55 + 67	Solenoid Valve 1 - N88-	<ul style="list-style-type: none"> Ignition switched OFF 	55 to 65 Ω	- Check routing of wiring according to wiring diagram - Replace valve body \Rightarrow page 38-36
	55 + 1			infinite Ω 1)	
7	54 + 67	Solenoid Valve 2 - N89-	<ul style="list-style-type: none"> Ignition switched OFF 	55 to 65 Ω	- Check routing of wiring according to wiring diagram - Replace valve body \Rightarrow page 38-36
	54 + 1			infinite Ω 1)	
8	9 + 67	Solenoid Valve 3 - N90-	<ul style="list-style-type: none"> Ignition switched OFF 	55 to 65 Ω	- Check routing of wiring according to wiring diagram - Replace valve body \Rightarrow page 38-36
	9 + 1			infinite Ω 1)	
9	47 + 67	Solenoid Valve 4 -	Ignition switched	55 to 65 Ω	- Check routing of wiring according

	N91-	• OFF			to wiring diagram - Replace valve body ⇒ page 38-36
47 + 1				infinite Ω 1)	

1) Switch multimeter to largest Ω (ohms) range

Switch to resistance measuring range 200 Ω

Test step	VAG 1598/18 sockets	Test of	<ul style="list-style-type: none"> Test conditions - Additional operations 	Specified value	Repairing malfunction
10	56 + 67	Solenoid Valve 5 - N92-	<ul style="list-style-type: none"> Ignition switched OFF 	55 to 65 Ω	<ul style="list-style-type: none"> - Check routing of wiring according to wiring diagram - Replace valve body \Rightarrow page 38-36
	56 + 1			infinite Ω 1)	
11	58 + 22	Solenoid Valve 6 - N93-	<ul style="list-style-type: none"> Ignition switched OFF 	4.5 to 6.5 Ω	<ul style="list-style-type: none"> - Check routing of wiring according to wiring diagram - Replace valve body \Rightarrow page 38-36
	58 + 1			infinite Ω 1)	
	22 + 1				
12	10 + 67	Solenoid Valve 7 - N94-	<ul style="list-style-type: none"> Ignition switched OFF 	55 to 65 Ω	<ul style="list-style-type: none"> - Check routing of wiring according to wiring diagram - Replace valve body \Rightarrow page 38-36
	10 + 1			infinite	

				Ω 1)	
13	23 + 29	Shiftlock Solenoid - N110-	<ul style="list-style-type: none"> Ignition switched OFF 	14 to 25 Ω	<ul style="list-style-type: none"> - Check routing of wiring according to wiring diagram - Replace Shiftlock Solenoid -N110- <p>⇒ Shift mechanism, servicing, page 37-1</p>

1) Switch multimeter to largest Ω (ohms) range

Switch to resistance measuring range 200 Ω					
Test step	VAG 1598/18 sockets	Test of	<ul style="list-style-type: none"> • Test conditions - Additional operations	Specified value	Repairing malfunction
14	1 + 16	Kick Down Switch -F8-	<ul style="list-style-type: none"> • Ignition switched OFF • Accelerator Pedal NOT depressed 	infinite Ω 1)	- Check routing of wiring according to wiring diagram - Adjust Accelerator Pedal cable, or replace ⇒ <i>Repair Manual, 2.0 Liter General, Engine, 1.8 Liter General, Engine or 2.8 Liter VR6 General, Engine, Repair Group 20</i>
			- Depress Accelerator Pedal as far as kickdown	less than 1.5 Ω	

1) Switch multimeter to largest Ω (ohms) range

Switch to resistance measuring range 20 K Ω					
Test step	VAG 1598/18 sockets	Test of	<ul style="list-style-type: none"> • Test conditions - Additional operations	Specified value	Repairing malfunction
15	20 + 65	Vehicle Speed Sensor (VSS)	<ul style="list-style-type: none"> • Ignition 		- Check wiring according to wiring diagram

-G68-

switched OFF

- Replace Vehicle Speed Sensor (VSS) -
G68- ⇒ [page 01-19, Fig. 23](#)

min.

0.8 K Ω

max.

0.9 K Ω

Switch to resistance measuring range 2 M Ω

Test step	VAG 1598/18 sockets	Test of	<ul style="list-style-type: none"> • Test conditions - Additional operations 	Specified value	Repairing malfunction	
16	6 + 67	Transmission Fluid Temperature Sensor -G93- (ATF)	<ul style="list-style-type: none"> • Ignition switched OFF • Transmission fluid (ATF) temperature approx. 20 ° C (68 ° F) 	0.247 M Ω	<ul style="list-style-type: none"> - Check wiring according to wiring diagram - Replace valve body \Rightarrow page 38-36 	
			- Switch to 200 K Ω measuring range			48.8 K Ω
			approx. 120 ° C (248 ° F)	7.4 K Ω		